

*This part requires two clamps, part numbers 212-300 and 248-300. See additional drawings for information on these clamps.

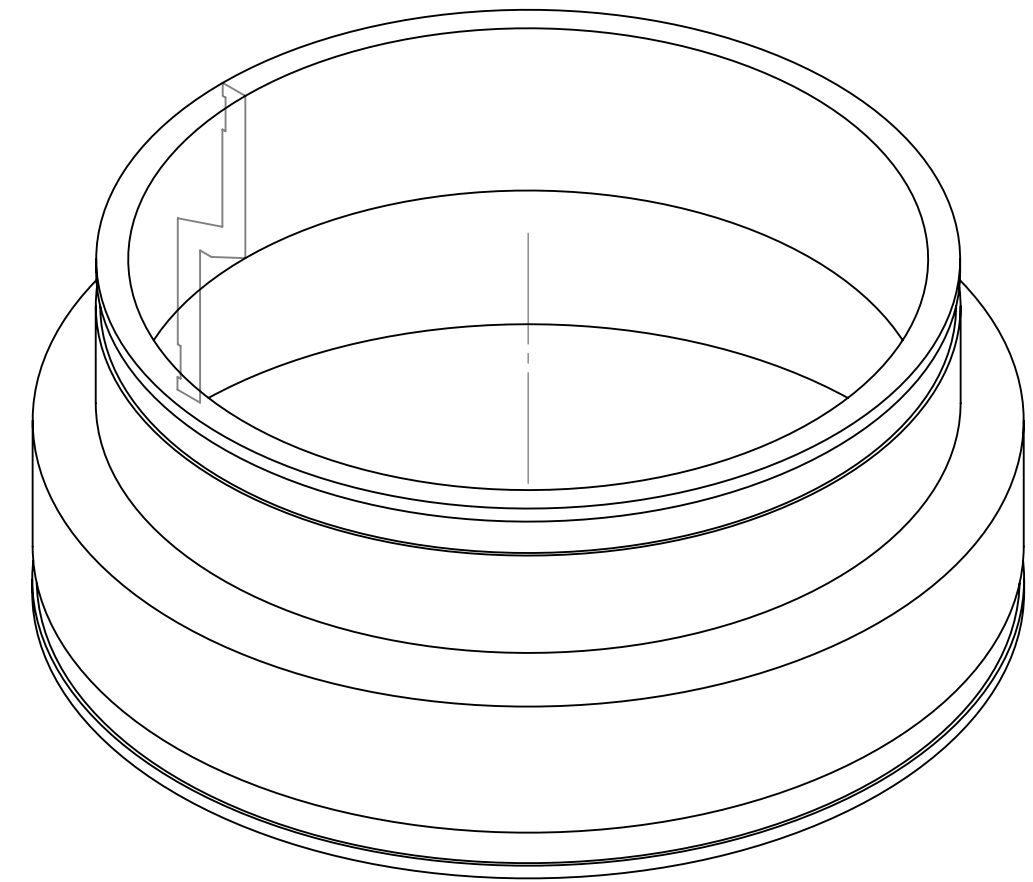

NOTES:
 -SOME HIDDEN LINES NOT SHOWN
 -BREAK ALL SHARP CORNERS
 -REPORT ALL CHANGES TO ENGINEERING

PROPRIETARY AND CONFIDENTIAL
 THE INFORMATION CONTAINED IN THIS DRAWING IS THE SOLE PROPERTY OF FERNCO, INC. ANY REPRODUCTION IN PART OR AS A WHOLE WITHOUT THE WRITTEN PERMISSION OF FERNCO, INC. IS PROHIBITED.

Part Weight	7.965 lbs.
Min/Max Temp.	-30/140 Degrees F
Pressure Tested	4.3 PSI
Material	Flexible PVC
Installation Torque	60" Lbs.
Conforms to ASTM	D5926, C1173
Box Quantity	40
Clamps used	300 Series



300 S. DAYTON ST.
 DAVISON, MI 48423
 PH: 810-653-9626
 FAX: 810-654-2616

TOLERANCES: .X= Fractional ± .XX= ±.02 .XXX= ±.030 ANG.= ±0.5° UNLESS OTHERWISE SPECIFIED		DESCRIPTION: Coupling 12" Clay x 12" PVC	
UNITS: INCHES		1002-1212	
SIZE: A	DESIGNER: D. Brady	SCALE: not to scale	
3RD ANGLE PROJECTION DO NOT SCALE DRAWING		CHECKER: DATE: 10/12/2007	SHEET 1 OF 1