

Custom Large Diameter Debris Caps

Custom fabricated from 6.5" and larger pipe O.D.

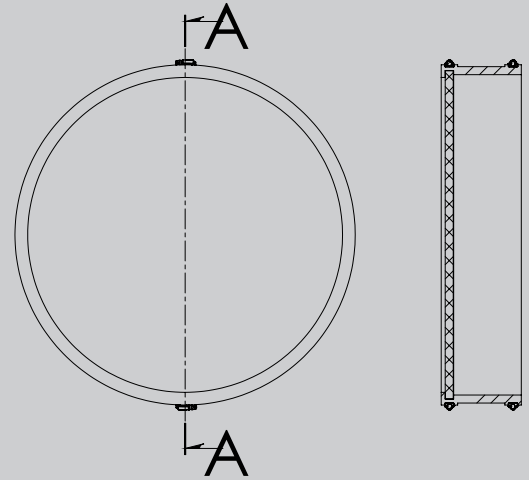

Feature Benefits:

- Cap Off and Secure Exposed Pipe Ends
- Ideal for Above or Below Ground Applications
- Use on Horizontal or Vertical Drum Lines
- Strong and Durable for Permanent or Temporary Installations
- Seal Off Sewer Lines, Stand Pipes, Sleeves, Landfill Wells...

Strong two-piece construction

- CAP Face: Rigid Durable PVC
 - Yield Strength - 12,800 psi, ASTM D790
 - Tensile Modulus – 411,000 psi, ASTM D638
 - Flexural Modulus – 481,000 psi, ASTM D790
- CAP Body
 - Flexible PVC Complying to ASTM D5926
- Clamps - All 300 Series Stainless Steel, 60"lb Installation Torque
- 24-inch Cap Tested to Withstand 1800lb Force for 24h, No Deformation



CUSTOM

Any size, any material